

PARSUN

Electric Outboard Motor

User Manual JOY1.2

Suzhou Parsun Power Machine Co., Ltd.

Thank you for choosing "PARSUN" electric outboard motor!
Thank you for your trust in Parsun and our products!

"PARSUN" products, produced with advanced technology and sophisticated process, perform excellently with strong power, high economical efficiency and safety. Please read this User's Manual carefully before using this product for the first time. The Manual will help you understand the product structure and facilitate correct operation and maintenance, thus helping your outboard motor keep good working conditions under various operating conditions.

"PARSUN" products continue to pursue perfection and quality improvement. As this Manual is based on the prototype at the time of publication, there may be minor differences between the actual motor you purchased and that described in the Manual. If you have any doubt, please consult our local dealers.

In any case, users shall not make any request to our company with the data, illustrations and instructions in this Manual as the legal basis.

Suzhou Parsun Power Machine Co., Ltd.

Index

JOY 1.2 IDENTITY.....	1
1. Product introduction.....	2
1.1 Product list.....	2
1.2 Main components.....	4
1.3 Specification information.....	4
2. Installation.....	6
2.1 Outboard motor's installation.....	6
2.2 Battery installation.....	7
3. Operation.....	8
3.1 Pre-use inspection.....	8
3.2 Startup.....	9
3.3 Driving.....	9
3.4 Shutdown.....	10
3.5 Trim angle adjustment of outboard motor.....	11
3.6 Handle angle adjustment.....	11
4. Liquid Crystal Display.....	13
5. Battery.....	15
5.1 Charging.....	15
5.2 Sleep mode and awakening.....	15
5.3 Precautions.....	16
6. Transportation and Storage.....	17
6.1 Transportation.....	17
6.2 Storage.....	17
7. Maintenance.....	18
7.1 Matters needing attention:.....	18
7.2 Propeller inspection and replacement.....	18
8. Emergency Handling.....	20

8.1 Impact damage	20
8.2 Accidental falling into water	20
8.3 Low voltage protection	20
9. Trouble shooting	21
9.1 Common problems and solutions.....	21
9.2 Fault codes and measures	21
10. Warranty	22

JOY 1.2 IDENTITY

The serial number is printed on a label which is fixed to the port side of the clamping bracket. Such number is recorded in a blank space of the label to help you order spare parts from dealers or to be used as a reference when the motor is stolen.

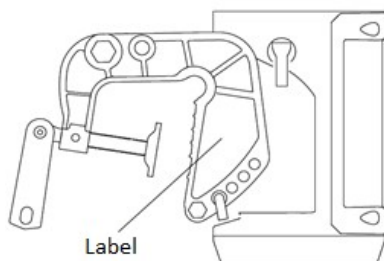

PARSON

Electric Outboard Motor

Model: JOY 1.2
S/N: EX12345678
Rated Power: 1200W
Rated Voltage: 36V
MRF Address: No.567 Liangang Road,
SND Suzhou 215121, China
Produced in 2022
Made in China

CE

The number is expressed as follows



S/N □□ □□□□□□□□



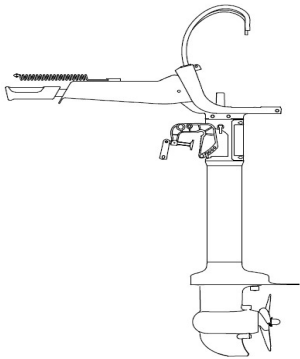
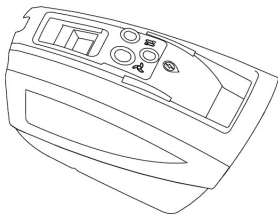

1. Product introduction

JOY1.2 is a convenient and efficient electric outboard motor, equipped with ternary lithium battery with high energy density, with maximum speed reaching 8.5km/h. The handle is also equipped with a liquid crystal display screen to better display important parameters.

1.1 Product list

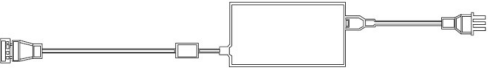
There will be the following parts in the product package you purchased. If there are any missing parts, please contact the local dealer.

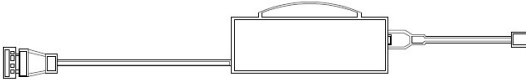
Item	Quantity	Diagram
Electric outboard motor	1 piece	
Battery	1 piece	
Safety switch	1 piece	

<p>Standard charger</p>	<p>1 piece</p>	
<p>Packing list User's manual Warranty card Quality certificate</p>	<p>1 set</p>	
<p>Fast charger (purchased separately)</p>	<p>1 piece</p>	
<p>Solar charger (purchased separately)</p>	<p>1 piece</p>	

1.2 Main components

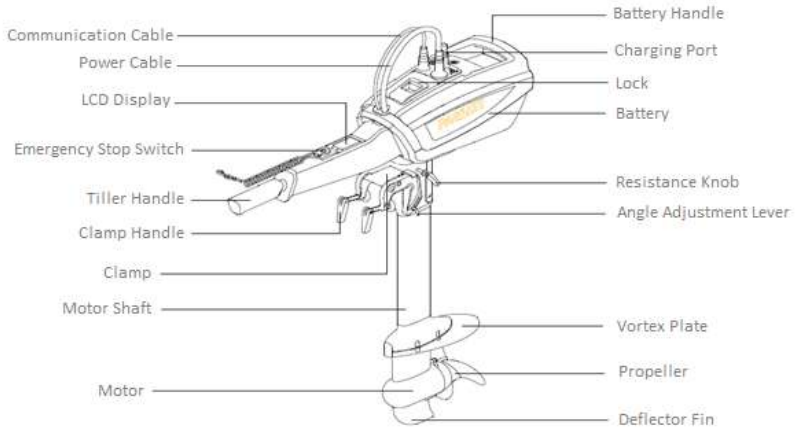

1.3 Specification information

JOY1.2 motor	
Rated voltage	36V
Rated input power	1.2kW
Rated current	33A
Peak thrust	320N
Equivalent gasoline outboard motor	3hp
Speed regulation mode	Stepless speed change
Type of motor	DC brushless motor
Control mode	Tiller handle
Net weight	19.5kg
Dimensions (L × W × H)	943mm×264mm×992mm (S) 943mm×264mm×1113mm (L)
Propeller diameter/pitch	235 mm / 76.2mm

JOY1.2 battery	
Battery type	Lithium battery
Rated capacity	1440Wh
Rated voltage	36V
Cycle life	≥ 500 cycles of charge and discharge
Charging time	≤6H
Minimum operating voltage	26V
Maximum operating voltage	42V
Battery weight	8.6Kg
Temperature range	Charging: 0°C ~ 45°C Discharging: -20°C ~ 60°C

JOY1.2 standard charger	
Input voltage	100~240VAC
Input voltage frequency	50~60Hz
Output voltage	42VDC
Output current	5A
Input power	210W
Temperature range	Working: -10°C~45°C Storage: -30°C~70°C

JOY1.2 fast charger	
Input voltage	100~240VAC
Input voltage frequency	50~60Hz
Output voltage	42VDC
Output current	20A
Input power	1000W
Temperature range	Working: -10°C~45°C Storage: -30°C~70°C

2. Installation

2.1 Outboard motor's installation

Step 1:

Install the outboard motor at the center line of the stern plate to ensure the balance of the ship. If the stern plate of the ship is asymmetrical, please consult the local dealer for guidance.

Note: Do not switch on the power supply in advance when installing the outboard motor, so as to avoid accidents.

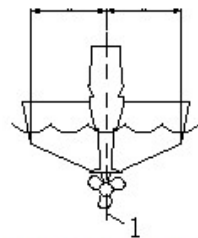

1. Center line (keel line)

Step 2:

Control the height of the vortex plate of the outboard motor at a position greater than 150mm from the bottom of the ship. The installation height determines the operation efficiency of ship. If the installation height is too high, eddy current will be generated and thrust will be reduced. If the installation height is too low, water resistance will increase, thus reducing engine efficiency.

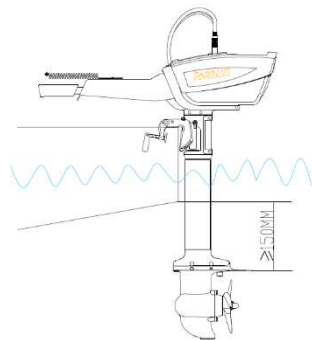

Step 3:

Tighten the clamping screw of stern plate clockwise to secure the outboard motor. Because the clamping screw will be loose due to engine vibration, check whether the clamping screw is loose from time to time during engine operation.

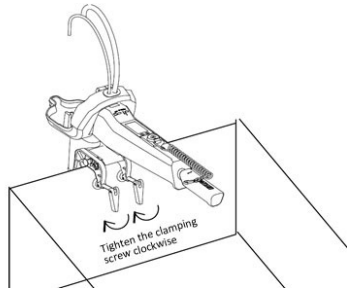

2.2 Battery installation

Step 1:

Lift the battery's upper snap, align the slot under the battery with the post on the outboard motor, then lower the battery and loosen the snap, as shown in the following figure.

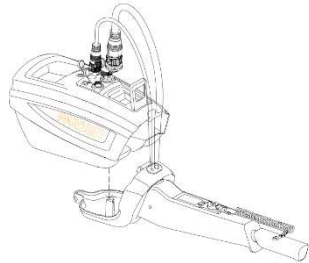

Step 2:

Connect the power cord and communication cord on the outboard motor to the battery; press the interface and the interface will automatically lock, as shown in the figure.

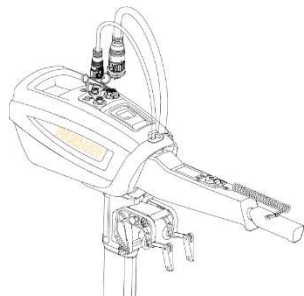

3. Operation

3.1 Pre-use inspection

- Please check whether the battery is fully charged.
- Please ensure that this product is correctly locked in the correct position on the stern plate of the boat.
- Please check whether the propeller is locked.
- Please check whether the battery module is fastened and whether the battery interface is connected correctly.
- Please check whether the throttle is in zero position.
- Please check whether the throttle handle can rotate smoothly.
- Please check whether the joints are in good condition without improper aging.
- Please check whether the battery interface is dry to avoid short circuit.

3.2 Startup

Press and hold the  key at the bottom of the handle screen, and release the key after hearing the prompt tone. The screen lights up and the motor starts.



3.3 Driving

Set the handle to zero position and fasten the magnetic induction emergency stop switch on the operator's hand.



Warning:

Please make sure there are no swimmers or obstacles in the nearby waters before driving.



When the handle is in zero position, the motor does not rotate and the ship is in a stop state.

When the handle is turned counterclockwise from the zero position, the ship moves forward and accelerates, otherwise it decelerates.

When the handle is turned clockwise from the zero position, the ship travels in the opposite direction and accelerates, otherwise it decelerates.

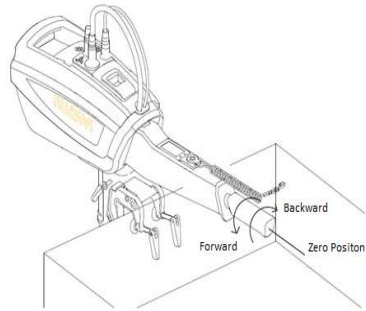

Note: Before turning on the power supply, the speed control handle must be in the zero position; otherwise, the motor will not turn after turning on the power supply.

3.4 Shutdown

This product can be shut down manually or automatically.

Manual shutdown: Press and hold the  button below the screen on the handle for 2 seconds. After hearing the prompt tone, release the button, the screen goes out and the shutdown is completed.

Automatic shutdown: When the outboard motor is stopped, the screen will automatically turn off after 1 hour, and the shutdown will be completed.

3.5 Trim angle adjustment of outboard motor

Remove the trim adjusting rod on the clamping bracket, which has four holes. Adjust the outboard motor to a suitable position, and then insert the trim adjusting rod into the corresponding hole to complete the adjustment.

Note: Do not turn on the power supply when adjusting the trim angle, so as to avoid accidents.

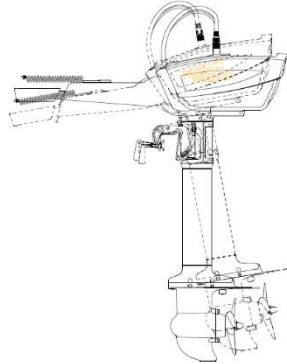

3.6 Handle angle adjustment

The handle of this product has the function of adjusting the angle up and down, but it is not detachable.

When sailing, the handle can be rotated up or down by up to 45°. When rotating up, the handle can be directly lifted up. When rotating downward, the handle needs to be stretched outward and then rotated down.

Note: When rotating 45° down, the handle will automatically keep the current angle, and you need to press it down to continue.

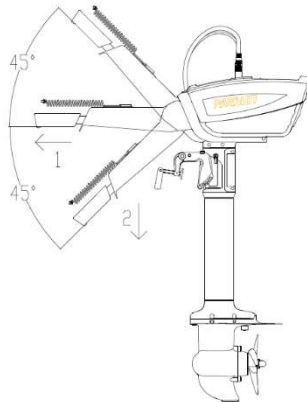

When transporting, the handle can be rotated downward by 90° for convenience. Before rotating, stretch the handle outward and then rotate it downward. When rotating to 45°, the handle automatically keeps the current angle. Press the handle hard at this time, and the handle can continue to rotate downward.

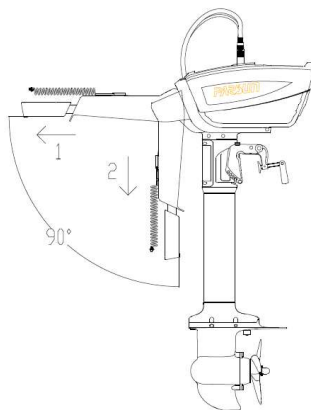

Note: The handle of this product is not detachable.







4. Liquid Crystal Display



Detailed description

Button	Function
	When this product is turned off, press and hold this button (about 2 seconds) to start it. When this product is turned on, press and hold this button (about 2 seconds) to shut it down.
	When this product is turned on, press this button once to turn on the backlight of the screen, and press it again to turn off the backlight.

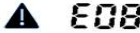
Identification	Function
----------------	----------

 15%	<p>The charging sign is on the left side, and the electric quantity display is on the right side. There are five grids in total, and the corresponding electric quantity of each grid is 0 ~ 20%, 20 ~ 40%, 40 ~ 60%, 60 ~ 80% and 80 ~ 100% respectively</p>
 7.2km/h	<p>Display the current speed when the ship speed is greater than 3km/h, and the display varies with the ship speed.</p>
 E08	<p>Alarm code, not displayed when there is no fault; see 9.2 - Fault codes and measures for details</p>
 600w	<p>Display the current power, which changes with the rotation of the handle.</p>
 1h30m	<p>Display the remaining time, which varies with the motor power</p>

5. Battery

5.1 Charging

When the battery power is low, the battery needs to be charged. The battery can be taken out and charged separately, or it can be connected to the outboard motor for charging. For the sake of battery life, the outboard motor should be in a shutdown state when charging.

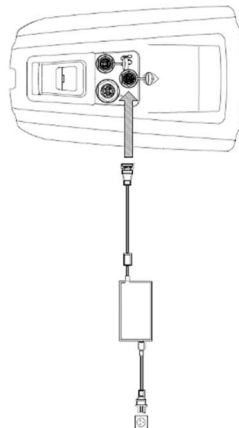

Please connect the charger to the socket and the battery charging port respectively.

Charger indicator light	Description
The red light is always on	Charging the battery
The green light is always on	Charging completed, or battery temperature protection triggered.

Note: 1. When the battery temperature is higher than 55°C, the battery will not be charged. After the battery cools down, it will automatically resume the charging function.

2. After charging, the charging port must be reliably covered with a cover to avoid damage to the charging port and failure to charge.

5.2 Sleep mode and awakening

Unplug the communication cable from the socket of the battery box, and the battery goes to sleep mode to keep low power consumption. Connect the communication cable to the socket of the battery box again, and the battery will wake up.

When the battery is connected with the machine and does not work for 48 hours continuously, the battery will enter sleep mode and keep low power consumption. At this time, the LCD screen cannot be lit and the motor cannot run. To wake up the battery, unplug and then plug the communication cable on the battery or connect the battery to the charger for charging.

5.3 Precautions

- ◆ Do not use damaged batteries.
- ◆ Do not knock or squeeze the battery.
- ◆ Do not use an unofficial charger to charge the battery.
- ◆ Do not keep the battery in wet or immersed environment for a long time.
- ◆ Do not disassemble and repair the battery without permission. If necessary, contact the local dealer.
- ◆ Keep the conductor away from the battery interface to avoid damaging the battery components.
- ◆ After using the battery, cover the battery interface with the protection cover.
- ◆ Do not use the battery below 26V.
- ◆ Before long-term storage, charge the battery to 60% and keep the ambient temperature at 15°C-25°C.
- ◆ For long-term storage, fully charge and fully discharge the battery every 3 months to keep the battery active. After that, keep the battery power at about 60%. Note that this operation can effectively improve the battery life.
- ◆ After long-term storage, please charge the battery to 100% before using it.
- ◆ Do not leave the battery in a high temperature or high pressure container, such as in an outdoor car exposed to the sun.
- ◆ Please dispose of the discarded batteries properly according to local laws and regulations.

6. Transportation and Storage

6.1 Transportation

To avoid collision damage, please use the original packaging scheme at the time of shipment to pack the outboard motor before transportation.

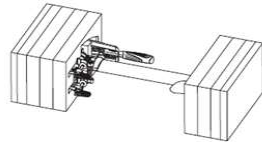

Note: Please carry or transport batteries in strict accordance with national and local regulations.

Do not transport damaged or abnormal lithium batteries.

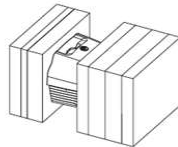

6.2 Storage

When outboard motors are stored for longer periods (two months or more), several important procedures must be performed to prevent excessive damage. It is recommended that outboard motors be maintained by an authorized dealer prior to storage, but users may operate the following procedures with limited tools.

1. Clean the outside of outboard motor with clear water
2. Install the outboard motor on the test water tank.
3. Inject clear water into the water tank to a level higher than the vortex plate.
4. Start the engine and flush the cooling system.
5. Place the outboard motor in a dry and well-ventilated place to avoid direct sunlight.

7. Maintenance

7.1 Matters needing attention:

1. Carry out regular maintenance to make your outboard motor keep the best working condition and prolong its service life.
2. Do not start the outboard motor in shallow water area near the shore, and adjust the motor to 70° to avoid touching the water bottom. After the underwater depth is enough to use the motor, adjust it to the appropriate gear and start it.
3. After using this product in seawater, please clean the underwater part with fresh water in time to reduce corrosion.

7.2 Propeller inspection and replacement



Warning:

Before inspecting, removing or installing the propeller, ensure that the engine shall not start accidentally. For example, you can cut off the power supply and remove the emergency stop switch. When loosening or tightening the propeller nut, do not block the propeller by hand, but place a board between the anti-vortex plate and the propeller to prevent it from rotating.

Inspection steps:

1. Check each blade of the propeller for wear, eddy current or exhaust erosion or other damage

2. Check whether the propeller shaft is damaged.
3. Check whether the spline safety pin is worn or damaged.
4. Check whether there is fishing line winding on the propeller shaft.
5. Check whether the oil seal on the propeller shaft is damaged.

Removing propeller:

1. Pull the cotter pin straight and pull it out with a tool.
2. Remove propeller nut, gasket and mounting pad (if any).
3. Remove propeller and thrust washer.

Installing propeller:

1. Apply marine grease or anti-corrosion grease on propeller shaft.
2. Install mounting pad (if any), thrust washer and propeller to propeller shaft.
3. Install mounting pad (if any) and gasket.
4. Screw on the propeller nut and align it with the hole in the propeller shaft. Insert a new cotter pin into the hole and bend the end of the cotter pin.

Note: Before installing the propeller, make sure to install the thrust washer, so as to prevent the underwater device shell and propeller from being damaged. Make sure to use a new cotter pin and bend its end firmly to prevent the propeller from falling off and losing.

8. Emergency Handling

8.1 Impact damage

If the outboard motor is accidentally impacted underwater during operation, please take the following measures.

1. Stop the motor immediately, and check whether the mechanical parts of the motor are damaged and whether the control system can be controlled normally.
2. Drive carefully and slowly back to the nearest dock or shore.
3. Contact the authorized agent for maintenance, and ensure that the motor works normally after the maintenance before reuse.

8.2 Accidental falling into water

If the overboard motor accidentally falls into the water during use, please take the following measures.

1. Stop the machine immediately and disconnect the power supply.
2. Contact the authorized agent for maintenance, and ensure that the motor works normally after the maintenance before reuse.

8.3 Low voltage protection

When the battery voltage is lower than the minimum voltage that enables the outboard motor to work normally, the outboard motor will automatically stop working to avoid over discharge of the battery. If you are far away from the shore at this time, it is recommended to wait for about 10 minutes. After the battery voltage recovers to some extent, you can turn on the motor with a power of less than 100W to return to shore.

9. Trouble shooting

9.1 Common problems and solutions

Common problem	Solution
The propeller does not rotate	<ol style="list-style-type: none">1. Check whether sundries such as wires or aquatic plants are wrapped around the propeller, and then clean up the propeller.2. Check whether the battery power is too low and charge the battery in time.3. Check whether the emergency stop switch is placed in place.
Excessive noise and shaking of outboard motor	<ol style="list-style-type: none">1. Check whether the propeller is firmly fixed. If it is loose, reinstall the propeller.2. Check whether the motor shaft is bent. If there is deformation, please contact the after-sales department of our company.3. Disconnect the power supply and turn the propeller by hand. If the propeller cannot turn, please contact the after-sales department of our company.

9.2 Fault codes and measures

Fault code	Cause	Solution
DTC:E01	Battery temperature too high	After waiting for the battery temperature to drop, the fault code will disappear.
DTC:E02	Motor temperature too high	After waiting for the motor temperature to drop, the fault code will disappear.
DTC:E03	The cell voltage too low	A discharge protection mode. The fault code will disappear after battery charging

DTC:E04	The cell voltage too high	A discharge protection mode. The fault code will disappear after stopping battery charging.
DTC:E05	Motor control circuit fault	Please contact Parsun's authorized dealer.
DTC:E07	Propeller jamming	Turn the throttle to zero position after clearing sundries wrapped around the propeller.
DTC:E08	Battery communication failure	Please contact Parsun's Authorized dealer.
DTC:E09	Motor communication failure	Please contact Parsun's Authorized dealer.

10. Warranty

Parsun undertakes limited warranty for quality problems caused by materials or craftsmanship of its products.

The warranty period of the whole motor is 1 year, starting from the date of original purchase note of the first-hand buyer.

Wearing parts (propeller, anode, etc.) are not covered by the warranty.

Accidents, misuse, malicious misuse, serious physical damage, water inflow or unauthorized repair are not covered by the warranty.

Faults caused by falling, improper maintenance or improper storage are not covered by the warranty.